



TOPONE

Catalog 2025

Self-drilling Screws

- ***Metal to Metal***
- ***Metal to Timber***

Self-drilling Screws – M2M fastening (Screws for metal)

SDS-1.1.HEW-1016
SDS-1.2.HEW-1019
SDS-1.3.HEW-1025

Valley / Cladding fastening

- Carbon steel screws for fastening steel sheets to steel substrates
- For light duty application

Specification:

- Gauge #10
- #10-16x16
- #10-16x19
- #10-16x25

| d (mm) | TPI | Length | |
|-----------|-----|--------|--------|
| | | (mm) | (inch) |
| 4.8 | 16 | 16 | 5/8" |
| | | 19 | 3/4" |
| | | 25 | 1" |

Adapter in use: Magnetic Hex Socket (5/16')

Washer: E.P.D.M

Coating

RS

Ruspert

Point

#3

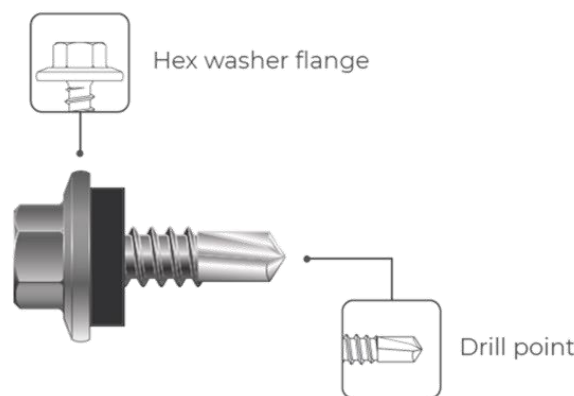
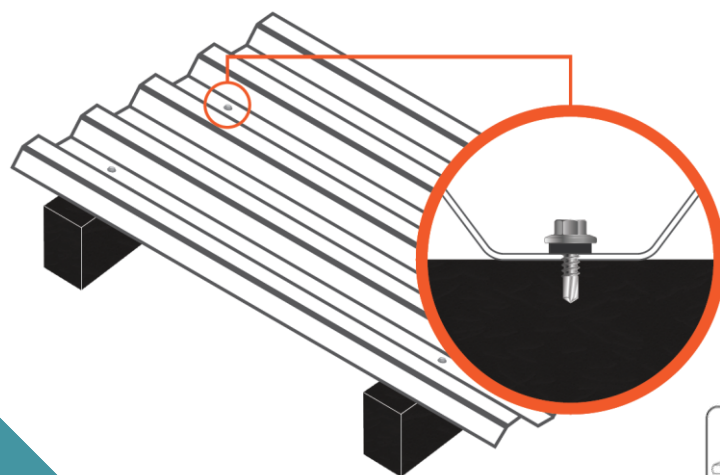

SST 500 -2000h
Kesternich 7 – 20 cycles

SS

Stainless Steel

YZ

Yellow Zinc

B

Phosphate

RS

Ruspert

ZN

Zinc

Self-drilling Screws - M2M fastening (Screws for metal)

SD-2.1.HEW-1219
SD-2.2.HEW-1225
SD-2.3.HEW-1235

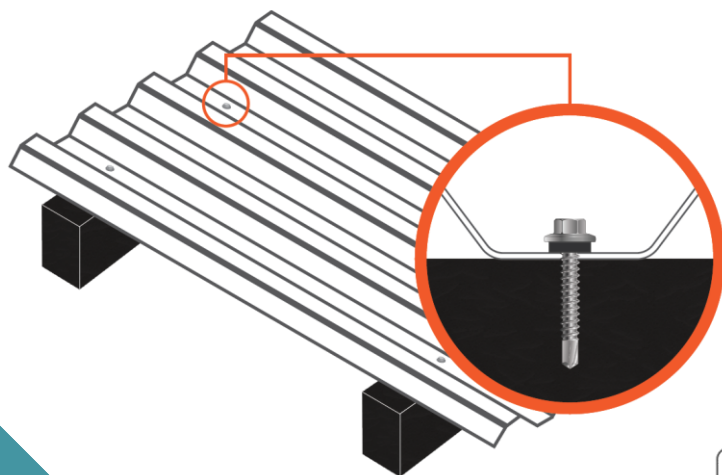

Valley / Cladding fastening

- Carbon steel screws for fastening steel sheets to steel substrates
- For light duty application

Specification:

- Gauge #12
- #12-14x19
- #12-14x25
- #12-14x35

| d (mm) | TPI | Length | |
|-----------|-----|--------|--------|
| | | (mm) | (inch) |
| 5.5 | 14 | 19 | 3/4" |
| | | 25 | 1" |
| | | 35 | 1-3/8" |

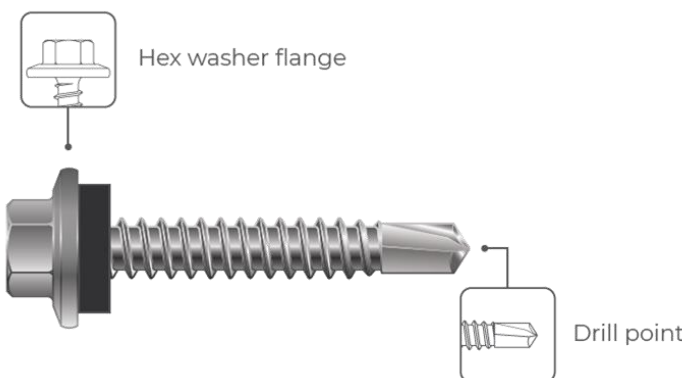

SST 500 -2000h
Kesternich 7 - 20 cycles

Adapter in use: Magnetic Hex Socket (5/16')

Washer: E.P.D.M washer Aluminum bonded washer



Point
#3

SS

Stainless Steel

YZ

Yellow Zinc

B

Phosphate

RS

Ruspert

ZN

Zinc

Self-drilling Screws – M2M fastening (Screws for metal)

SDS-3.1.HEW-1250
SDS-3.2.HEW-1255
SDS-3.3.HEW-1268

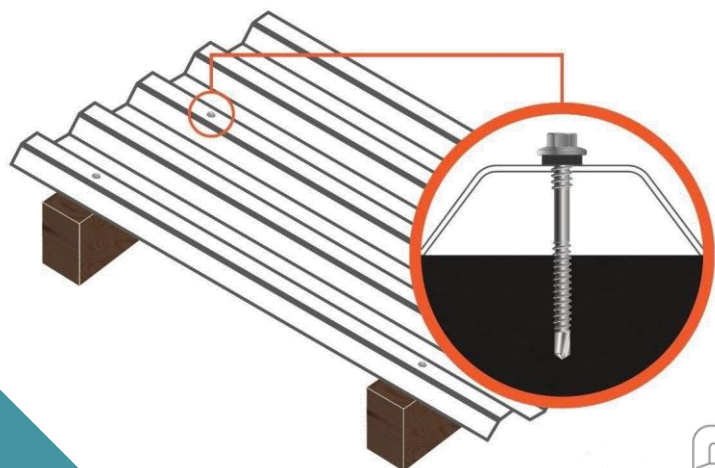

Crest fastening

- Carbon steel screws for fastening steel sheets to steel substrates

Specification:

- Gauge #12
- #12-14x50
- #12-14x55
- #12-14x68

| d (mm) | TPI | Length | |
|-----------|-----|--------|---------|
| | | (mm) | (inch) |
| 5.5 | 14 | 50 | 2" |
| | | 55 | 2-3/16" |
| | | 68 | 2-3/4" |

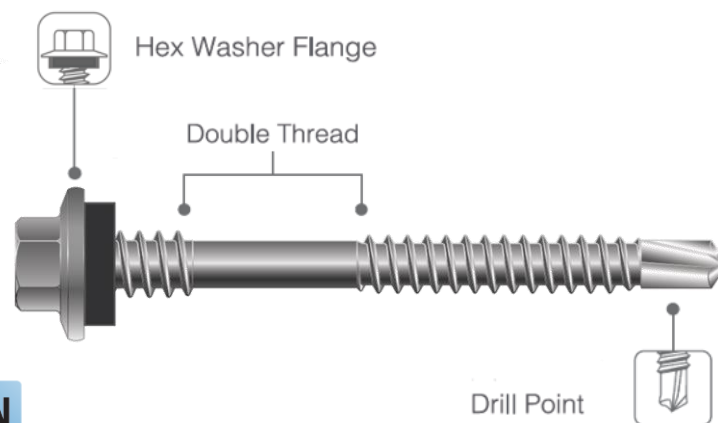

SST 500 -2000h
Kesternich 7 – 20 cycles

Adapter in use: Magnetic Hex Socket (5/16')

Washer: E.P.D.M / bonded washer



Point
#3

SS

Stainless
Steel

YZ

Yellow
Zinc

B

Phosphate

RS

Ruspert

ZN

Zinc

Self-drilling Screws – M2M fastening (Screws for metal)

SDS-4.1.HEW-1519.R

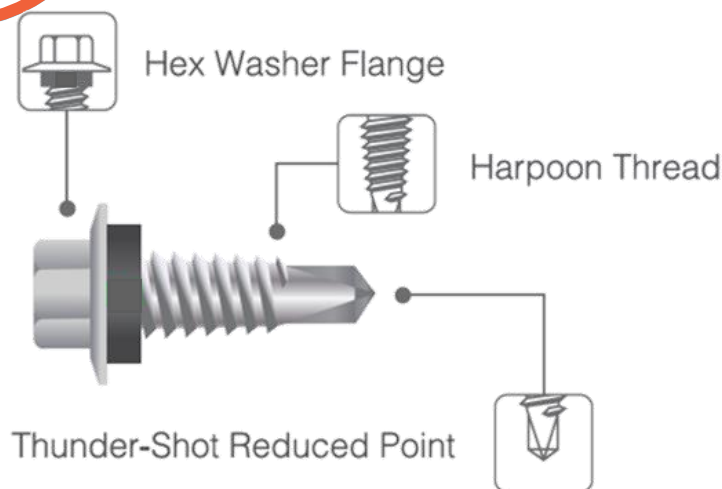
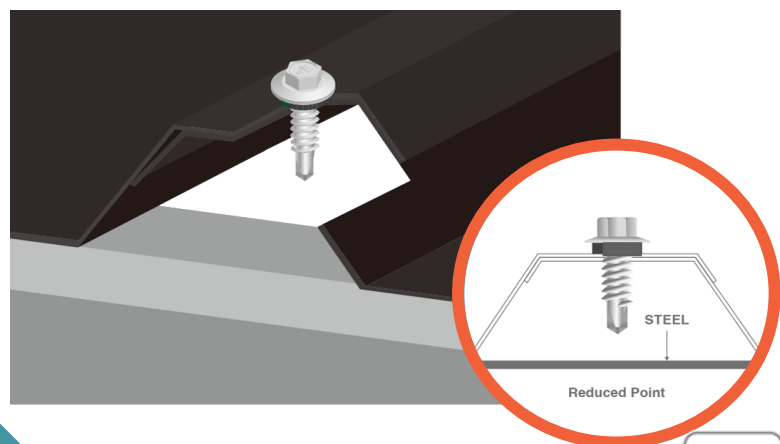

Stitching Screws

- Carbon steel screws for fastening steel sheets to steel substrates
- For light duty application such as fastening panel to panel side lap, panel to end lap light gauge, lightweight steel, ...

Specification:

- Gauge #15
#15-15x19

| d (mm) | TPI | Length | |
|--------|-----|--------|--------|
| | | (mm) | (inch) |
| 6.5 | 15 | 19 | 3/4" |

Adapter in use: Magnetic Hex Socket (5/16')

Washer: E.P.D.M washer Aluminum bonded washer



Point

#3

SS

Stainless Steel

YZ

Yellow Zinc

B

Phosphate

RS

Ruspert

ZN

Zinc

SST 500 -2000h
Kesternich 7 – 20 cycles

Self-drilling Screws – M2M fastening (Screws for metal)

SDS-5.1.W-1016
SDS-5.2.W-1022
SDS-5.2.W-1032
SDS-5.2.W-1050

Concealed fastening

- Carbon steel screws for fastening steel sheets to steel substrates
- Residential steel frame construction
- For light duty

Specification:

- Gauge #10
- #10-24x16
- #10-24x22
- #10-24x32
- #10-24x50

| d (mm) | TPI | Length | |
|-----------|-----|--------|--------|
| | | (mm) | (inch) |
| 4.8 | 24 | 16 | 5/8" |
| | | | |
| | | | |
| | | | |

Adapter in use: Philips Bit (PH2+)

SST 1000h

Kesternich 10 - 12 cycles

Coating

RS

Ruspert

Point

#3

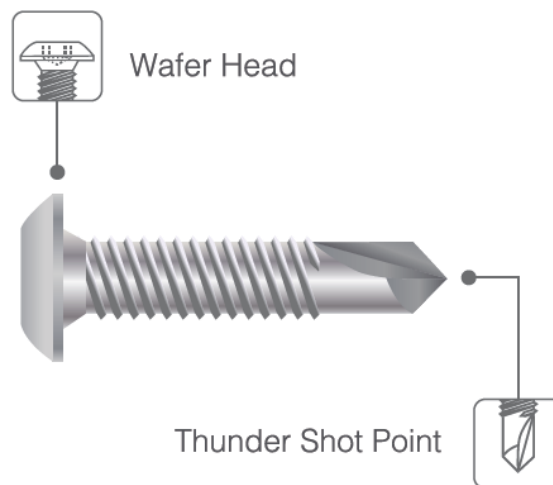
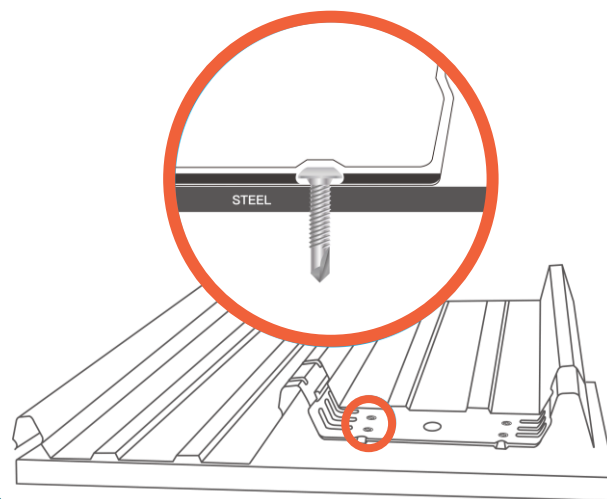

SS

Stainless Steel

YZ

Yellow Zinc

B

Phosphate

RS

Ruspert

ZN

Zinc

Self-drilling Screws – M2M fastening (Screws for metal)

SDS-6.1.T-0813
SDS-6.2.T-0819

Truss head fastening

- Carbon steel screws for fastening steel, polycarbonate, panel sheets, ... to steel substrates
- Residential steel frame construction
- For light duty

Specification:

- Gauge #8
#8-18x13
#8-18x19

| d (mm) | TPI | Length | |
|-----------|-----|--------|--------|
| | | (mm) | (inch) |
| 4.2 | 18 | 13 | 1/2" |
| | | 19 | 3/4" |

Adapter in use: Philips Bit (PH2+)

Coating

RS

Ruspert

Point

#1

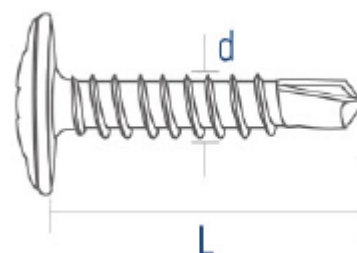
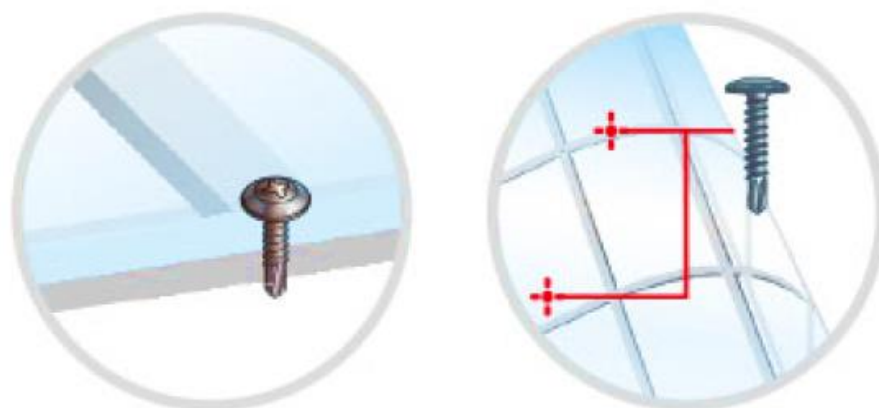

SS

Stainless Steel

YZ

Yellow Zinc

B

Phosphate

RS

Ruspert

ZN

Zinc

Self-drilling Screws – M2M fastening (Screws for metal)

SDS-7.1.C-0838.W

Countersunk Wing

- Carbon steel screws for fastening wood mansard, plywood, floor sheet, ... to steel substrates
- Flat head design countersunk and seats flush in wood

Specification:

- Special winged fasteners ream a hole in wood
- Gauge #8
#8-18x38

| d (mm) | TPI | Length | |
|-----------|-----|--------|--------|
| | | (mm) | (inch) |
| 4.2 | 18 | 38 | 1-1/2" |

Adapter in use: Philips Bit (PH2+)

SST 500 - 2000h
Kesternich 7 – 20 cycles

Coating **RS** Point **#1**
Ruspert

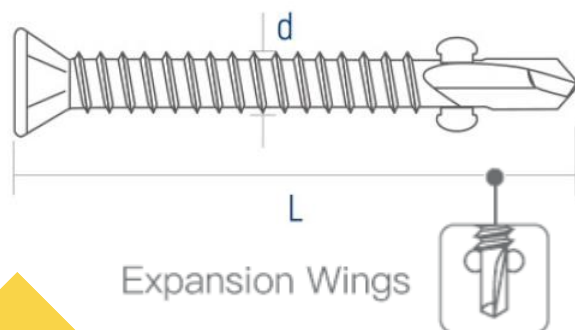
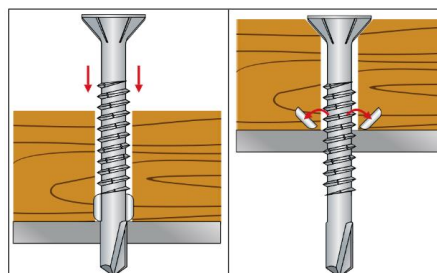
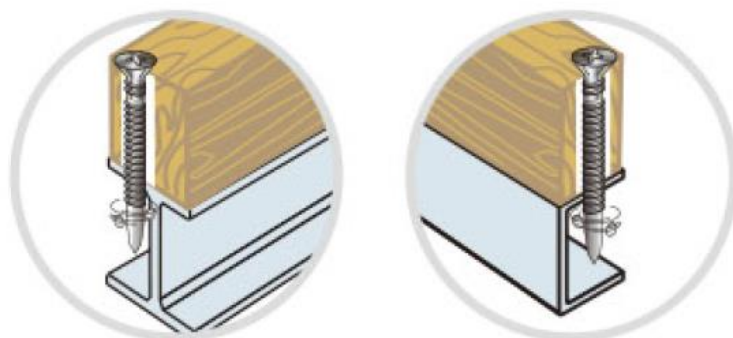

SS

Stainless Steel

YZ

Yellow Zinc

B

Phosphate

RS

Ruspert

ZN

Zinc

Self-drilling Screws – M2M fastening (Screws for metal)

SDS-8.1.HDW-1240.W
SDS-8.2.HDW-1255.W

Plastic skylight fastening

- Carbon steel screws for reaming a thermal expansion hole on plastic skylight sheets and fix onto sheet substrates .

Specification:

- Special winged fasteners ream a hole in wood
- Gauge #12
#12-14x40
#12-14x55

| d (mm) | TPI | Length | |
|-----------|-----|--------|---------|
| | | (mm) | (inch) |
| 5.5 | 14 | 40 | 1-5/8" |
| | | 55 | 2-3/16" |

Adapter in use: Magnetic Hex Socket (5/16')

Washer: OD 25mm Dome E.P.D.M,

Coating

Point

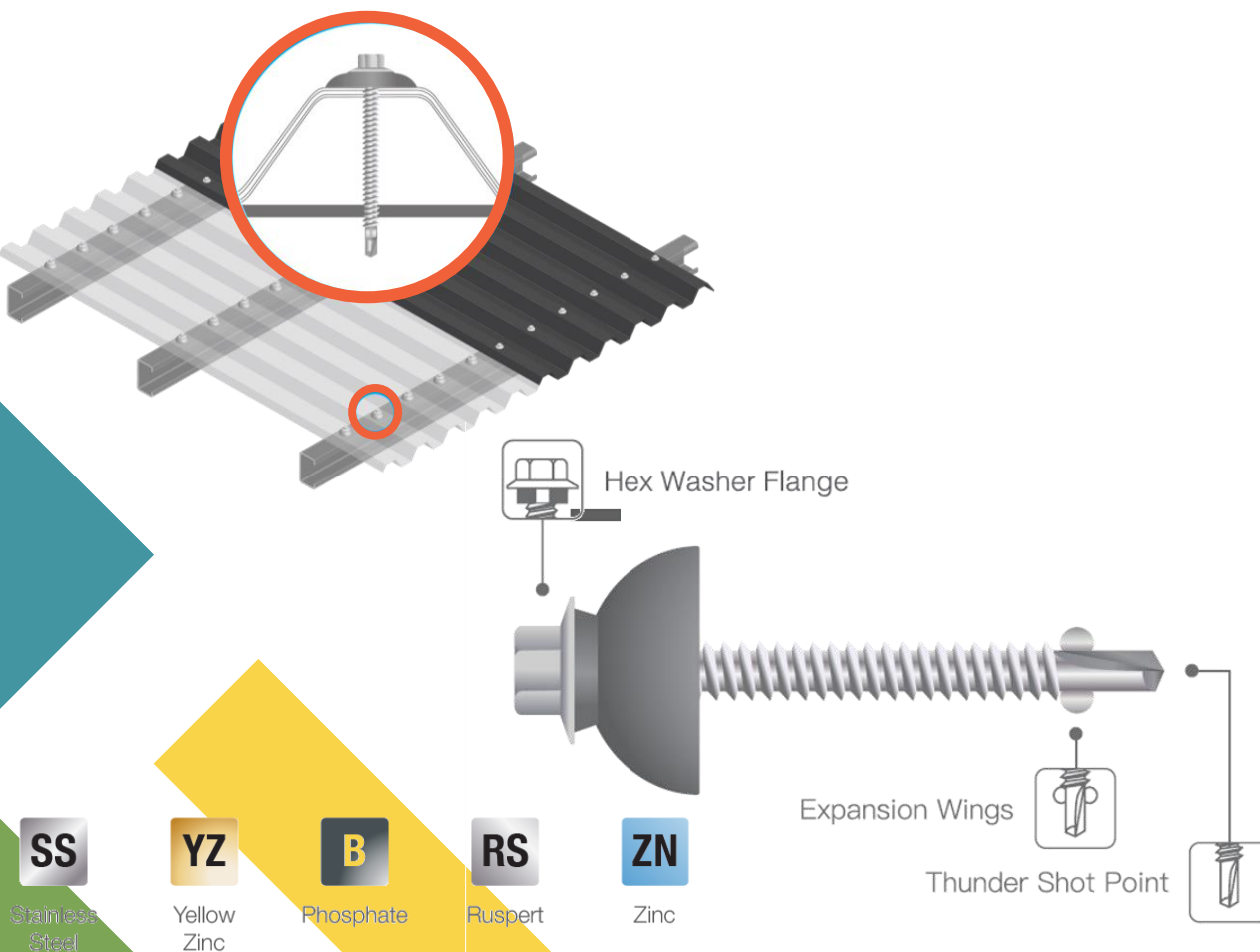

SST 500 -2000h
Kesternich 7 – 20 cycles



RS
Ruspert

#3

Self-drilling Screws - M2M fastening (Screws for metal)

SDS-9.1.HNW-1220.B

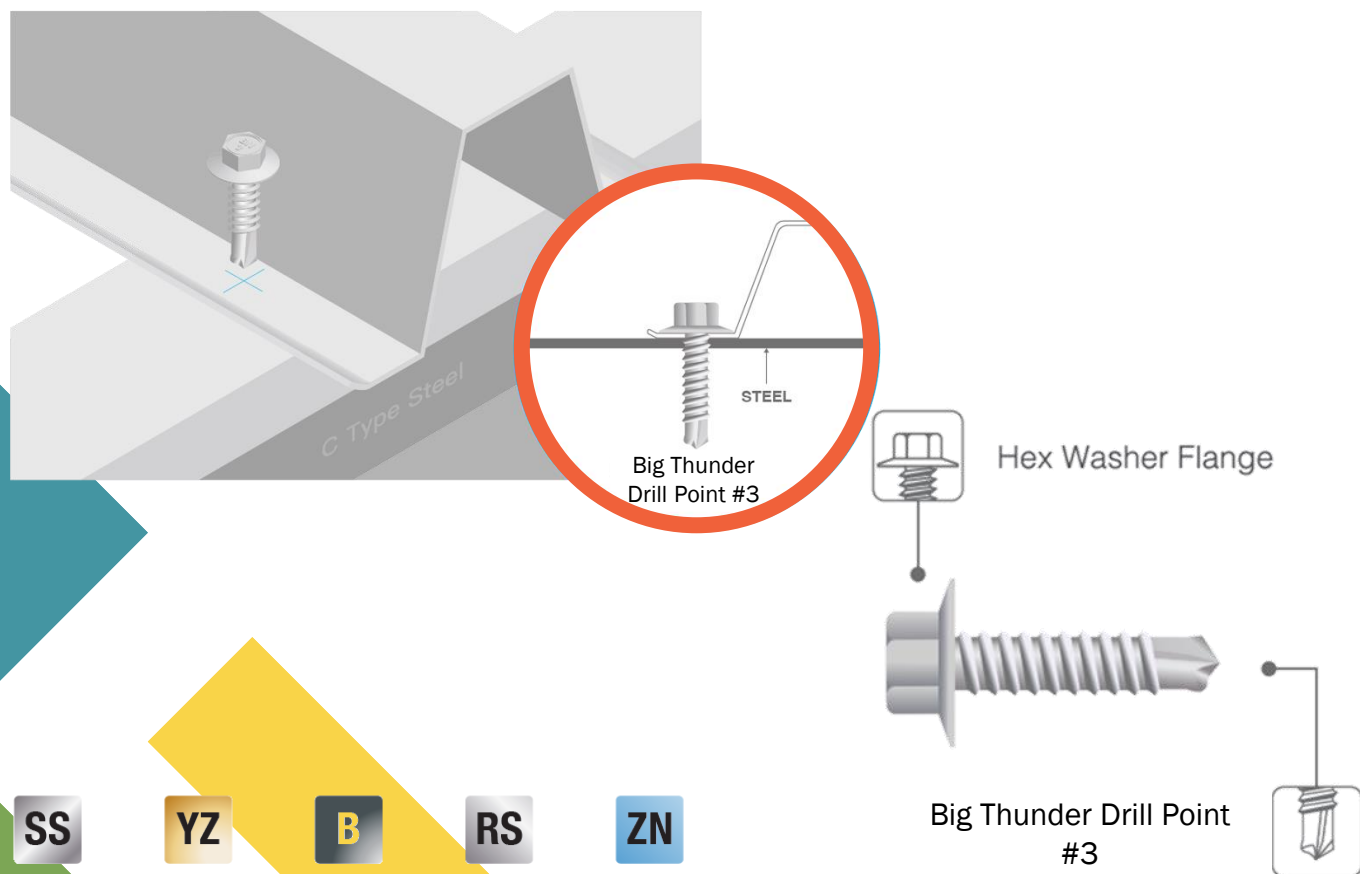

Truss fastening

- Carbon steel screws for fastening steel trusses to steel which thick from 0.75mm to 1.6mm
- For light duty application

Specification:

- Gauge #12
#12-14x20

| d (mm) | TPI | Length | |
|-----------|-----|--------|--------|
| | | (mm) | (inch) |
| 5.5 | 14 | 20 | 3/4" |

Adapter in use: Magnetic Hex Socket (5/16')

SST 500 -2000h
Kesternich 7 - 20 cycles

Coating

RS

Ruspert

Point

#3

SS

Stainless Steel

YZ

Yellow Zinc

B

Phosphate

RS

Ruspert

ZN

Zinc

Self-drilling Screws – M2M fastening (Screws for metal)

SDS-10.1.HEW-1238.B

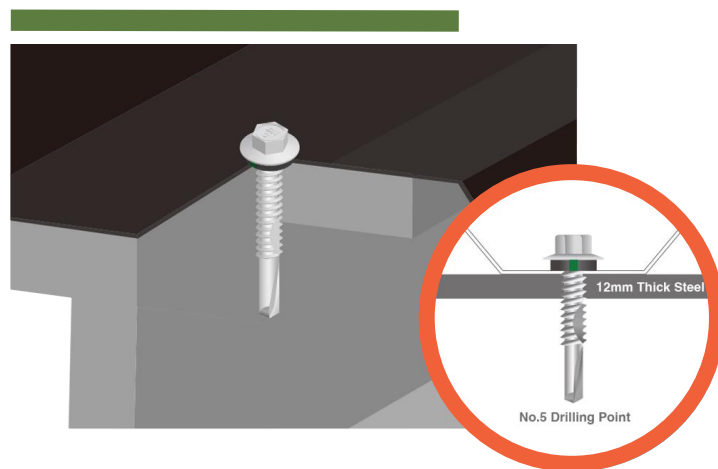

Thick steel fastening

- Carbon steel screws for fastening cladding to thick steel which thick max 12mm
- For heavy duty application

Specification:

- Gauge #12
#12-24x38
- Head type:
 - Hex Washer Flange
 - Wafer

| d (mm) | TPI | Length | |
|-----------|-----|--------|--------|
| | | (mm) | (inch) |
| 5.5 | 24 | 38 | 1-1/2" |

Adapter in use: Magnetic Hex Socket (5/16')

Washer: E.P.D.M



SST 500 -2000h
Kesternich 7 – 20 cycles

Coating

RS

Ruspert

Point

#5

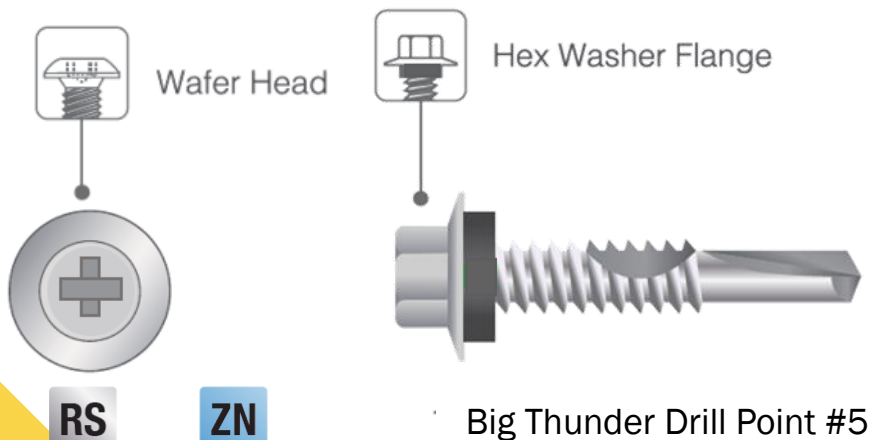

SS

Stainless Steel

YZ

Yellow Zinc

B

Phosphate

RS

Ruspert

ZN

Zinc



Self- tapping Screws

Metal to Timber

Self-tapping Screws – M2T fastening (Screws for timber)

STS-1.1.HEW-1019

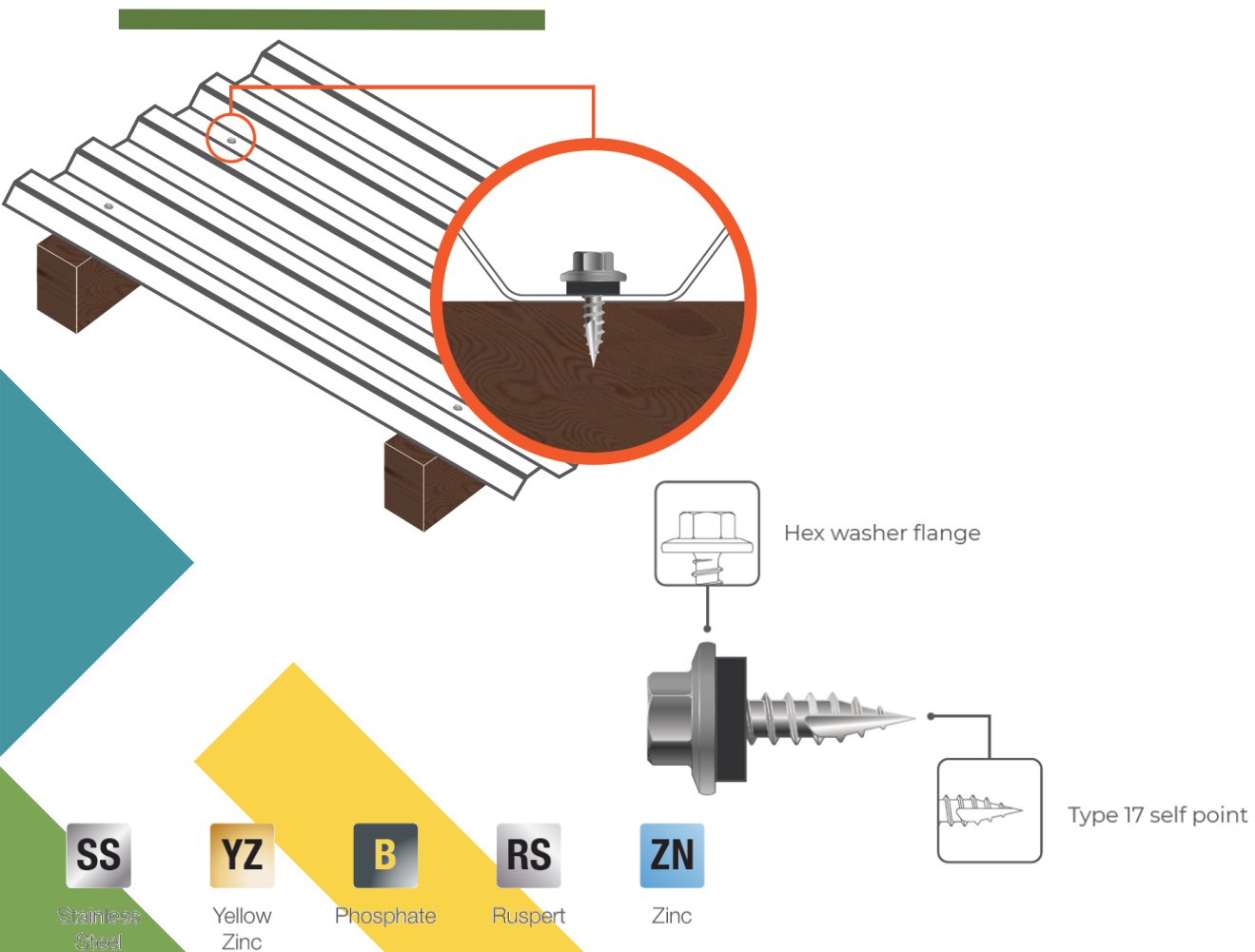

Valley/ Cladding fastening

- Carbon steel screws for fastening steel sheets to timber substrates
- For light duty application

Specification:

- Gauge #10
#10-12x19

| d (mm) | TPI | Length | |
|-----------|-----|--------|--------|
| | | (mm) | (inch) |
| 4.8 | 12 | 19 | 3/4" |

Adapter in use: Magnetic Hex Socket (5/16')

Washer: E.P.D.M,

Coating



RS

Ruspert

SST 500 -2000h

Kesternich 7 – 20 cycles

Self-tapping Screws – M2T fastening (Screws for timber)

STS-2.1.HEW-1250
STS-2.2.HEW-1255
STS-2.3.HEW-1268

Crest fastening Screws

- Carbon steel screws for fastening steel sheets to timber substrates

Specification:

- Gauge #12
- #12-11x50
- #12-11x55
- #12-11x68

| d (mm) | TPI | Length | |
|-----------|-----|--------|---------|
| | | (mm) | (inch) |
| 5.5 | 11 | 50 | 2" |
| | | 55 | 2-3/16" |
| | | 68 | 2-3/4" |

Adapter in use: Magnetic Hex Socket (5/16')

Washer: E.P.D.M washer, Bonded washer

Coating



RS

Ruspert

SST 500 -2000h

Kesternich 7 – 20 cycles

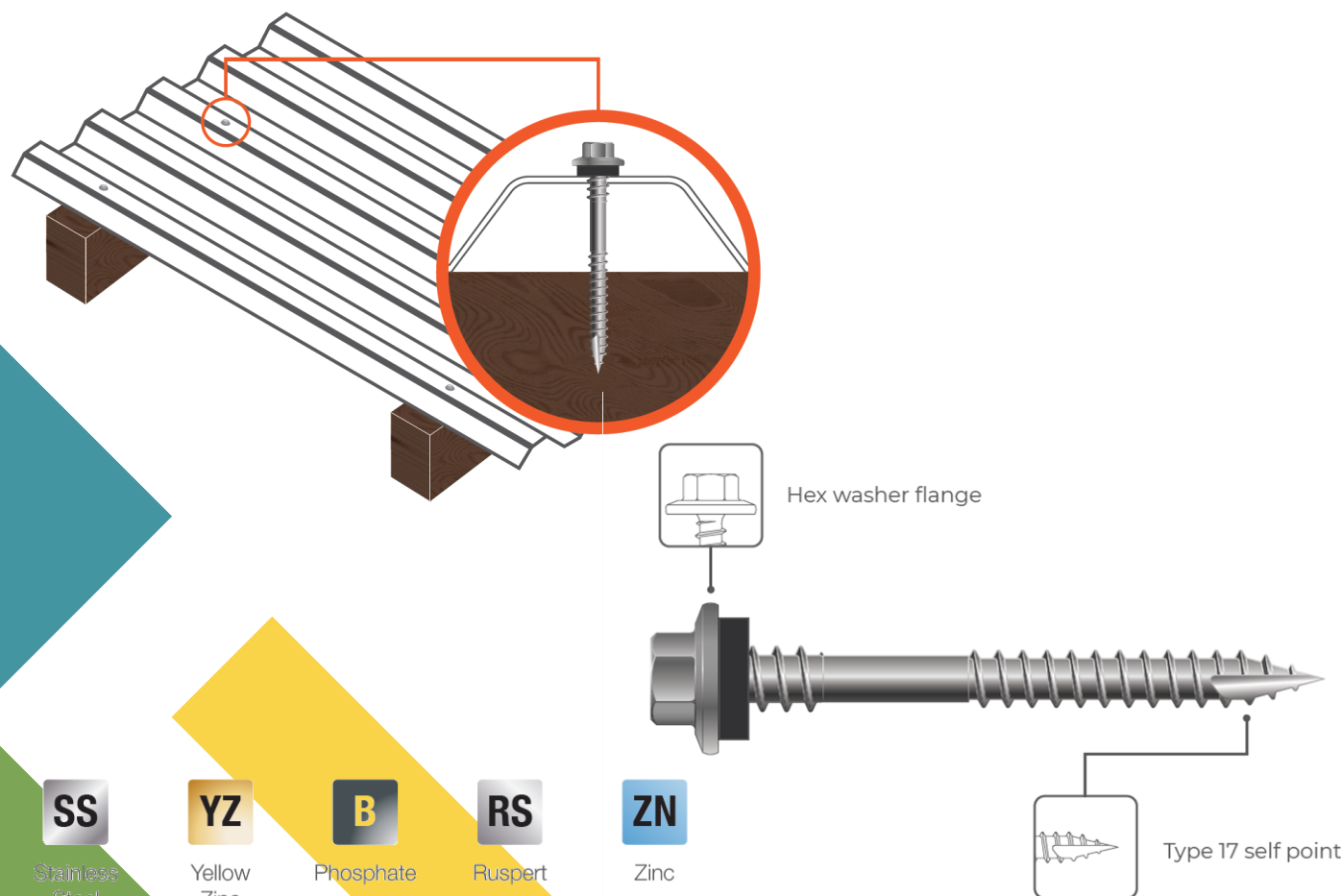

SS

Stainless Steel

YZ

Yellow Zinc

B

Phosphate

RS

Ruspert

ZN

Zinc

Type 17 self point

Drywall Screws

- ***Drywall to Metal***
- ***Drywall to Timber***

Drywall screws for thin metal

DW-1.1.B-0632
DW-1.2.B-0641

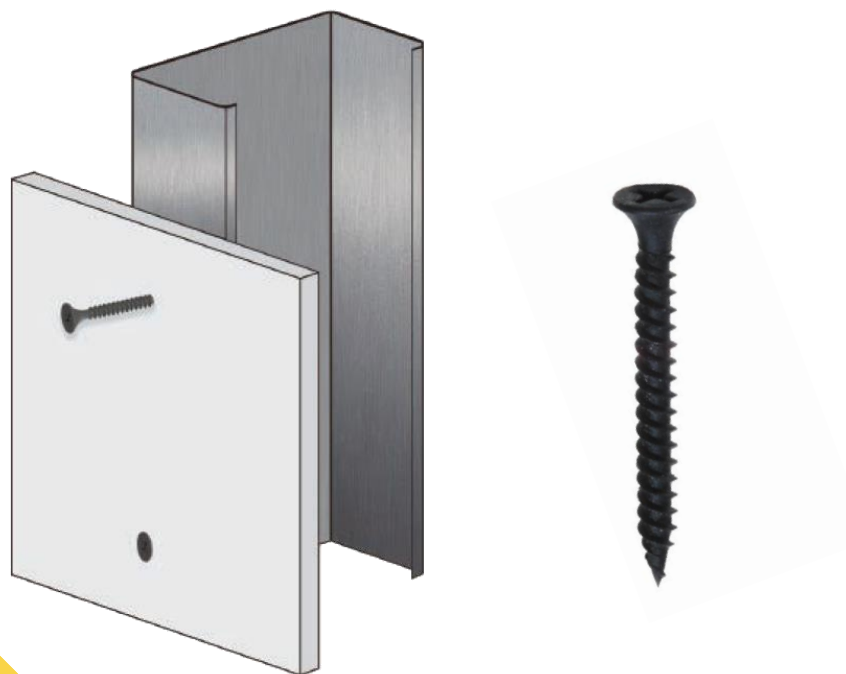

Bugle Head – Fine Thread

Carbon steel for fastening drywall to thin steel

Specification:

- Fine Thread
- Bugle head phillips
- #6x1-1/4" (M3.5x32mm)
- #6x1-5/8" (M3.5x41mm)

Adapter in use: Philips Bit (PH2+)

Coating

RS

Ruspert

SS

Stainless
Steel

YZ

Yellow
Zinc

B

Phosphate

RS

Ruspert

ZN

Zinc

Drywall screws for timber

DW-2.1.B-0632
DW-2.2.B-0641



Bugle Head – Coarse Thread

Carbon steel for fastening drywall to Timber

Specification:

- Coarse Thread
- Bugle head phillips
- #6x1-1/4" (M3.5x32mm)
- #6x1-5/8" (M3.5x41mm)

Adapter in use: Philips Bit (PH2+)

Coating

RS

Ruspert

SS

Stainless
Steel

YZ

Yellow
Zinc

B

Phosphate

RS

Ruspert

ZN

Zinc

Thank you



TOPONE

TOM TANG
Founder & CEO

📍 860 QL 1A st, Binh Tri Dong A ward,
Binh Tan Dist, HCM City, VietNam.

📞 Whatsapp: +84 933 888 239

✉️ tom@toponevn.com

🌐 <http://fastdrivescrew.com>



**TOPONE BUILDING MATERIAL TRADING
PRODUCTION COMPANY LIMITED**



- Head Office: 10/16 Thoai Ngoc Hau Street, Hoa Thanh Ward, Tan Phu District, Ho Chi Minh City, VietNam.
- Factory 1: 860 National Highway 1A, Binh Tri Dong A Ward, Binh Tan District, Ho Chi Minh City, VietNam.
- Factory 2: 142/1 My Phuoc Street - Tan Van, Binh Quoi B, Binh Chuan Ward, Thuan An City, Binh Duong Province
- Business number: 0313669293